

Online Data Sheet

Encoder WDGA 58E CANopen LIFT galv. isolation

www.wachendorff-automation.com/wdga58ecanliftgalv

Wachendorff Automation

... systems and encoders

- Complete systems
- Industrial rugged encoders to suit your application
- Standard range and customer versions
- Maximum permissible loads
- 48-hour express production
- Made in Germany
- Worldwide distributor network

Encoder WDGA 58E absolute CANopen LIFT galv. isolation, magnetic, with EnDra®- Technology



EnDra®
Technologie

CANopen LIFT

- EnDra® maintenance-free and environmentally friendly
- CANopen LIFT, Single- and Multiturn
- Communication Profile according to CiA 301
- Application Profile CANopen Lift CiA 417
- Single-/Multiturn (14 bit / 39 bit)
- Future-oriented technology with 32 Bit processor
- 2-colour-LED as indicator for operating condition and error message appropriate CiA 303-3

www.wachendorff-automation.com/wdga58ecanliftgalv

Mechanical Data

Housing

Flange	hollow shaft (blind-bored)
Flange material	aluminium
Housing cap	steel case chrome-plated, magnetic shielding
Torque supports	incl. 1 torque support WDGDS10019
- 1. Spring plate compensation	axial: ±1.2 mm, radial: ±0.2 mm
- Max. operating speed	6000 rpm up to max. protection rating +80 °C
Housing	Ø 58 mm

Shaft(s)

Shaft material	stainless steel
Starting torque	approx. 1.6 Ncm at ambient temperature, approx. 2.226 in-ozf at ambient temperature
Fixing	permanently attached clamping ring

Shaft	Ø 6 mm
Advice	with adapter sleeve
Shaft length	L: 17 mm
Insertion depth min.	10 mm
Insertion depth max.	19 mm
Max. Permissible shaft loading radial	80 N
Max. Permissible shaft loading axial	50 N

Shaft	Ø 6.35 mm, Ø 1/4"
Advice	with adapter sleeve
Shaft length	L: 17 mm, L: 0.669 in
Insertion depth min.	10 mm, 0.394 in
Insertion depth max.	19 mm, 0.748 in
Max. Permissible shaft loading radial	80 N, 8.158 kp
Max. Permissible shaft loading axial	50 N, 5.099 kp

Shaft	Ø 7 mm
Advice	with adapter sleeve
Shaft length	L: 17 mm
Insertion depth min.	10 mm
Insertion depth max.	19 mm
Max. Permissible shaft loading radial	80 N
Max. Permissible shaft loading axial	50 N

Shaft	Ø 8 mm
Advice	with adapter sleeve
Shaft length	L: 17 mm
Insertion depth min.	10 mm
Insertion depth max.	19 mm
Max. Permissible shaft loading radial	80 N
Max. Permissible shaft loading axial	50 N

Shaft	Ø 3/8", 9.525 mm, Ø 3/8"
Advice	with adapter sleeve
Shaft length	L: 17 mm, L: 0.669 in
Insertion depth min.	10 mm, 0.394 in
Insertion depth max.	19 mm, 0.748 in
Max. Permissible shaft loading radial	80 N, 8.158 kp
Max. Permissible shaft loading axial	50 N, 5.099 kp

Shaft	Ø 10 mm
Advice	with adapter sleeve
Shaft length	L: 17 mm
Insertion depth min.	10 mm
Insertion depth max.	19 mm
Max. Permissible shaft loading radial	80 N
Max. Permissible shaft loading axial	50 N

Shaft	Ø 12 mm
Shaft length	L: 17 mm
Insertion depth min.	10 mm
Insertion depth max.	19 mm
Max. Permissible shaft loading radial	80 N
Max. Permissible shaft loading axial	50 N

Shaft	Ø 14 mm
Shaft length	L: 17 mm
Insertion depth min.	10 mm
Insertion depth max.	19 mm
Max. Permissible shaft loading radial	80 N
Max. Permissible shaft loading axial	50 N

Bearings

Bearings type	2 precision ball bearings
Nominal service life	1 x 10 ⁹ revs. at 100 % rated shaft load 1 x 10 ¹⁰ revs. at 40 % rated shaft load 1 x 10 ¹¹ revs. at 20 % rated shaft load
Max. operating speed	6000 rpm

Electrical Data

Power supply/Current consumption	10 VDC up to 32 VDC: max. 100 mA
Power consumption	max. 1 W

Sensor data

Singleturn technology	innovative hall sensor technology
Singleturn resolution	16,384 steps/360° (14 bit)
Singleturn accuracy	< ±0.35°
Singleturn repeat accuracy	< ±0.20°
Intern cycle time	600 µs
Multiturn technology	patented EnDra® technology no battery and no gear.
Multiturn resolution	up to 262,144 revolution (18 bit) with high precision value up to 39 bit.

Environmental data

ESD (DIN EN 61000-4-2):	8 kV
Burst (DIN EN 61000-4-4):	2 kV
includes EMC:	DIN EN 61000-6-2 DIN EN 61000-6-3
Vibration: (DIN EN 60068-2-6)	50 m/s ² (10 Hz up to 2000 Hz)
Shock: (DIN EN 60068-2-27)	1000 m/s ² (6 ms)
Design:	according DIN VDE 0160
Turn on time:	<1,5 s

Interface

Interface:	CAN
Protocol:	CANopen <ul style="list-style-type: none"> • Communication profil CiA 301 • Application Profile CANopen LIFT CiA 417 V2.0 • Up to three virtual devices <i>car position unit (configurable)</i>
Node number:	1 up to 127 (default 4)
Baud rate:	50 kBaud up to 1 MBaud with automatic bit rate detection.
Advice:	The standard settings as well as any customization in the software can be changed via LSS (CiA 305) and the SDO protocol, e. g. PDOs, Scaling, Heartbeat, Node-ID, Baud rate, etc.
Programmable CAN transmission modes:	Synchronous mode: when a synchronisation telegram (SYNC) is received from another bus node, PDOs are transmitted independently. Asynchronous mode: a PDO message is triggered by an internal event. (e.g. change of measured valued, internal timer, etc.)

General Data

Weight	approx. 410 g, approx. 14.462 oz
Connections	connector outlet
Protection rating (EN 60529)	IP67, shaft sealed to IP65
Operating temperature	-40 °C up to +85 °C, -40 °F up to +176 °F
Storage temperature	-40 °C up to +100 °C, -40 °F up to +212 °F

More Information

General technical data	http://www.wachendorff-automation.com/gtd
Options	http://www.wachendorff-automation.com/acc

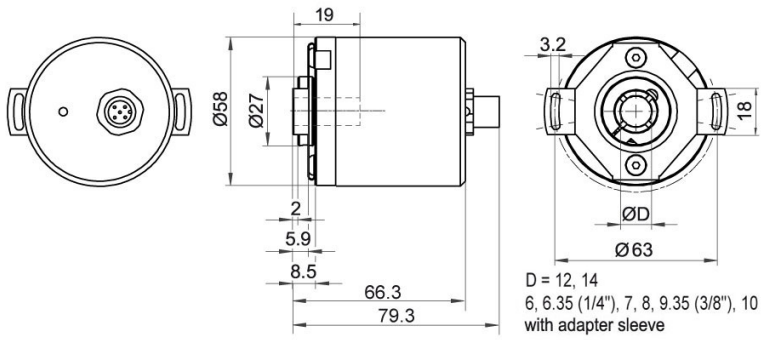
WDGA 58E CANopen LIFT galv. isolation, with M12x1, axial CB5, 5-pin

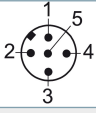
Description
CB5 axial, 5-pin, shield connected to encoder housing

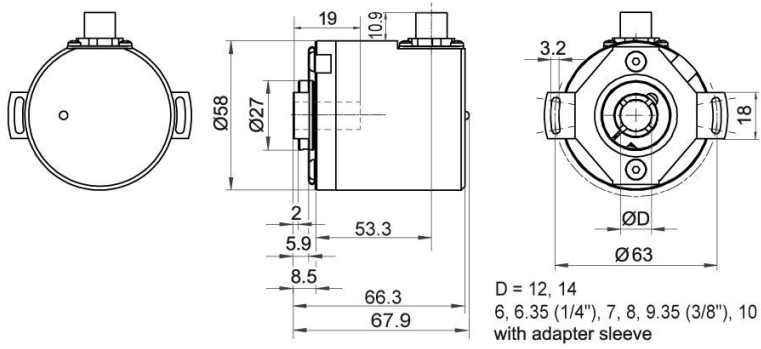
Assignments	
	CB5 
(+) Vcc	2
GND	3
CANHigh	4
CANLow	5
CANGND shield	1

WDGA 58E CANopen LIFT galv. isolation, with M12x1, radial CC5, 5-pin

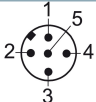
Description

CC5 radial, 5-pin, shield connected to encoder housing

Assignments	
	CC5 
(+) Vcc	2
GND	3
CANHigh	4
CANLow	5
CANGND shield	1

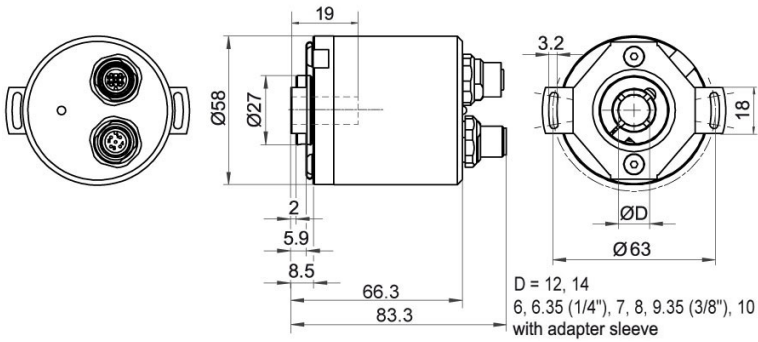
WDGA 58E CANopen LIFT galv. isolation, with 2x M12x1, axial DB5, 5-pin



Description

DB5 axial, 5-pin, shield connected to encoder housing

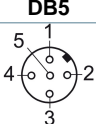
Assignments	
	
Female connector	M12x1, 5-pin
(+) Vcc	2
GND	3
CANHigh	4
CANLow	5
CANGND shield	1

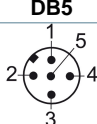
Assignments	
	
Connector	M12x1, 5-pin
(+) Vcc	2
GND	3
CANHigh	4
CANLow	5
CANGND shield	1

Options**120 Ohm terminating resistor****Order key**

The encoder WDGA 58E CANopen LIFT galv. is also available with fixed 120 Ohm terminating resistor.

AEO

Example Order No.	Type	Your encoder	
WDGA 58E	WDGA 58E	WDGA 58E	
	Shaft	Order key	
12	Ø 6 mm with adapter sleeve	06	
	Ø 6.35 mm Ø 1/4" with adapter sleeve	2Z	
	Ø 7 mm with adapter sleeve	07	
	Ø 8 mm with adapter sleeve	08	
	Ø 3/8", 9.525 mm Ø 3/8" with adapter sleeve	4Z	
	Ø 10 mm with adapter sleeve	10	
	Ø 12 mm	12	
	Ø 14 mm	14	
	Singleturn Resolution	Order key	
12	Singleturn resolution 1 Bit up to 14 Bit: (e. G. 12 Bit)	12	
	Multiturn Resolution	Order key	
18	Multiturn resolution 18 Bit	18	
	Data protocol	Order key	
CL	CANopen LIFT (galv. isolation)	CL	
	Software	Order key	
A	up to date release	A	
	Code	Order key	
B	binary	B	
	Power supply	Order key	
0	10 V up to 32 V (standard)	0	
	Galvanic isolation	Order key	
1	yes	1	
	Electrical connections	Order key	
CB5	Connector:		
	sensor-connector, M12x1, 5-pin, axial, IP67, shield connected to encoder housing	CB5	
	sensor-connector, M12x1, 5-pin, radial, IP67, shield connected to encoder housing	CC5	
	sensor-connector/female connector, 2x M12x1, 5-pin, axial, IP67, shield connected to encoder housing	DB5	
	Options	Order key	
	Without option	Empty	
	120 Ohm terminating resistor	AEO	

Example Order No.	WDGA 58E	12	12	18	CL	A	B	0	1	CB5	
--------------------------	----------	----	----	----	----	---	---	---	---	-----	--

WDGA 58E											Example Order No.
----------	--	--	--	--	--	--	--	--	--	--	--------------------------



For further information please contact our local distributor.
Here you find a list of our distributors worldwide.
http://www.wachendorff-automation.com/distributors_worldwide.html



Wachendorff Automation GmbH & Co. KG
Industriestrasse 7 • D-65366 Geisenheim

Phone: +49 67 22 / 99 65 25
Fax: +49 67 22 / 99 65 70
E-Mail: wdg@wachendorff.de
www.wachendorff-automation.de

