

Ultrasonic retro-reflective sensors

URAR 18P7912/S14G

dimension drawing

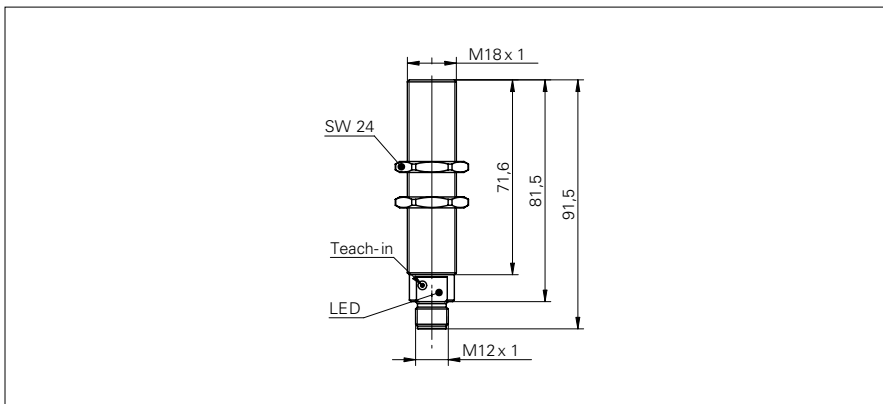

general data

special type	chemically resistant
scanning range s_d	0 ... 400 mm
reflector position S_{de}	120 ... 400 mm
repeat accuracy	< 1,5 mm
temperature drift	< 2 % S_{de}
response time t_{on}	< 25 ms
release time t_{off}	< 25 ms
sonic frequency	400 kHz
adjustment	Teach-in
alignment aid	target indication flashing
output indicator	LED green

electrical data

voltage supply range +Vs	12 ... 30 VDC
current consumption max. (no load)	35 mA
output circuit	PNP break function (NC)
output current	< 200 mA
voltage drop V_d	< 2 VDC
residual ripple	< 10 % V_s
short circuit protection	yes
reverse polarity protection	yes

mechanical data

type	cylindrical threaded
housing material	stainless steel 1.4435 (V4A)
width / diameter	18 mm
height / length	91,5 mm
connection types	connector M12
coating active face	Parylene
material O-ring	FFKM
front of sensor durable against pressure	6 bar, 20'000 cycle

ambient conditions

operating temperature	0 ... +60 °C
protection class	IP 67

photo



connection diagram

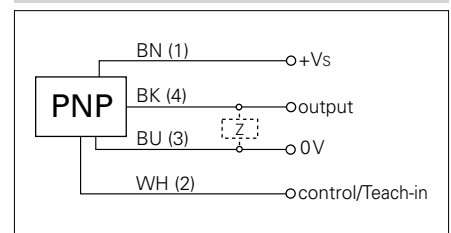

- internal and external Teach-in
- chemically resistant version