

Hall sensors

MTRM 16G2524/M150

dimension drawing

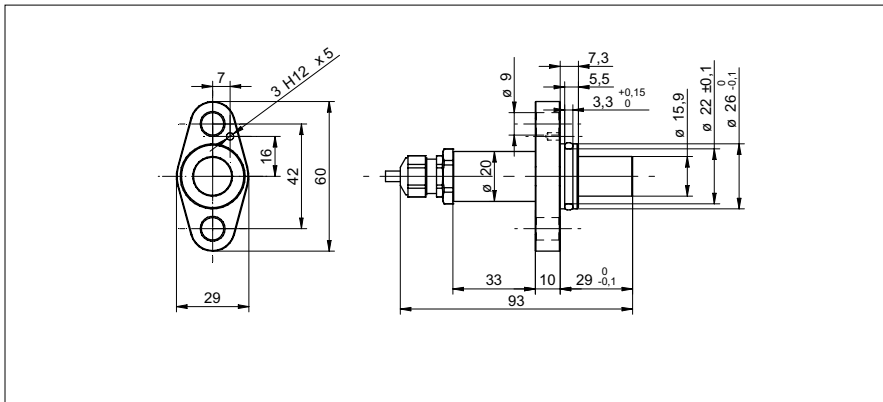

general data

version	full metal
sensor type	differential hall sensor
working distance max.	1,6 mm (module 1,5)
min. gear size	module 1,5
gear width	> 10 mm
gear material	ferromagnetic
gear shape	involute gear (DIN867)

electrical data

switching frequency range	2 ... 20 kHz
voltage supply range +Vs	8 ... 28 VDC
current consumption max. (no load)	20 mA
output A	push-pull
output B	push-pull
output current	< 30 mA
voltage drop Vd	< 5 VDC
short circuit protection	yes
reverse polarity protection	yes, Vs to GND

mechanical data

type	cylindrical, with flange
housing material	brass nickel plated
dimension	16 mm
housing length	93 mm
installation aid	pin hole
connection types	cable Radox, 2 m
front of sensor durable against pressure	20 bar

ambient conditions

operating temperature	-40 ... +120 °C
protection class (sensing face)	IP 68
protection class (sensor)	IP 67

photo



connection diagram

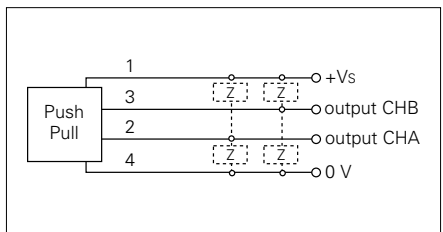

output signal

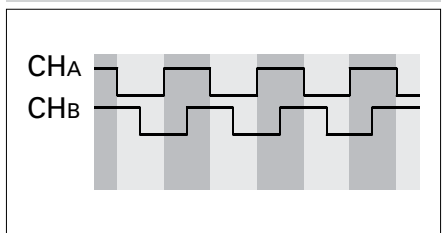

- Fulfilled standards:
 - EN 50155:2007 (class S1)
 - EN 50121-3-2:2006 tables 7,8,9
 - EN 61373:1999 (cat. 3)