

# Online Data Sheet

## Encoder WDG 145H

[www.wachendorff-automation.com/wdg145h](http://www.wachendorff-automation.com/wdg145h)

### **Wachendorff Automation**

#### **... systems and encoders**

- Complete systems
- Industrial rugged encoders to suit your application
- Standard range and customer versions
- Maximum permissible loads
- 48-hour express production
- Made in Germany
- Worldwide distributor network

# Encoder WDG 145H



- Thru-bore encoder for direct installation on large electric motors
- Maximum mechanical and electrical safety
- Highly interference-resistant when used with frequency converters
- Meets protection class IP5, optional IP64
- Full connection protection with 10 VDC up to 30 VDC
- With light reserve warning

[www.wachendorff-automation.com/wdg145h](http://www.wachendorff-automation.com/wdg145h)

Resolution	
Max. pulses per revolution PPR	up to 2500 PPR

Mechanical Data	
Housing	
Flange	hollow shaft (through-bored)
Flange material	aluminium
Housing cap	aluminium
Torque supports	incl. 3 torque supports WDGDS10001
- 1. Spring plate compensation	axial: ±0.8 mm, radial: ±0.2 mm
- 2. Cylinder pin 4 mm	needs accessories WDGDS10005
- Compensation	axial: ±0.5 mm, radial: ±1.5 mm, Max. operating speed: 800 rpm
Housing	Ø 145 mm

Shaft(s)	
Shaft material	stainless steel
Starting torque	approx. 1.5 Ncm at ambient temperature
Fixing	permanently attached clamping ring

Shaft	Ø 45 mm
Shaft length	L: 58 mm
Max. Permissible shaft loading radial	200 N
Max. Permissible shaft loading axial	100 N

Shaft	Ø 48 mm
Shaft length	L: 58 mm
Max. Permissible shaft loading radial	200 N
Max. Permissible shaft loading axial	100 N

Shaft	Ø 50 mm
Shaft length	L: 58 mm
Max. Permissible shaft loading radial	200 N
Max. Permissible shaft loading axial	100 N

Shaft	Ø 55 mm
Shaft length	L: 58 mm

Max. Permissible shaft loading radial	200 N
Max. Permissible shaft loading axial	100 N

Shaft	Ø 60 mm
Shaft length	L: 58 mm
Max. Permissible shaft loading radial	200 N
Max. Permissible shaft loading axial	100 N

Shaft	Ø 65 mm
Shaft length	L: 58 mm
Max. Permissible shaft loading radial	200 N
Max. Permissible shaft loading axial	100 N

Shaft	Ø 72 mm
Shaft length	L: 58 mm
Max. Permissible shaft loading radial	200 N
Max. Permissible shaft loading axial	100 N

Bearings	
Bearings type	2 precision ball bearings
Nominale service life	3 x 10 <sup>10</sup> revs. at 100 % rated shaft load 4 x 10 <sup>11</sup> revs. at 40 % rated shaft load 3 x 10 <sup>12</sup> revs. at 20 % rated shaft load
Max. operating speed	1600 rpm

Machinery Directive: basic data safety integrity level	
MTTF <sub>d</sub>	200 a
Mission time (TM)	25 a
Nominale service life (L10h)	3 x 10 <sup>12</sup> revs. at 20 % rated shaft load and 1600 rpm
Diagnostic coverage (DC)	0 %

Electrical Data	
Power supply/Current consumption	4,75 VDC up to 5,5 VDC: max. 70 mA
Power supply/Current consumption	10 VDC up to 30 VDC: max. 70 mA

Output circuit	TTL TTL, RS422 compatible, inv. HTL HTL, inv.
Pulse frequency	TTL 2500 ppr: max. 200 kHz HTL 2500 ppr: max. 200 kHz
Channels	AB ABN and inverted signals
Load	max. 40 mA / channel
Circuit protection	circuit type G24, H24, I24, R24 only

#### Accuracy

Phase offset	90° ± max. 7.5 % of the pulse length
pulse-/pause-ratio	50 % ± max. 7 %

#### General Data

Weight	approx. 1700 g up to 2500 g
Connections	cable or connector, radial
Protection rating (EN 60529)	IP54
Operating temperature	-20 °C up to +80 °C
Storage temperature	-30 °C up to +80 °C

#### More Information

General technical data

<http://www.wachendorff-automation.com/gtd>

Options

<http://www.wachendorff-automation.com/acc>

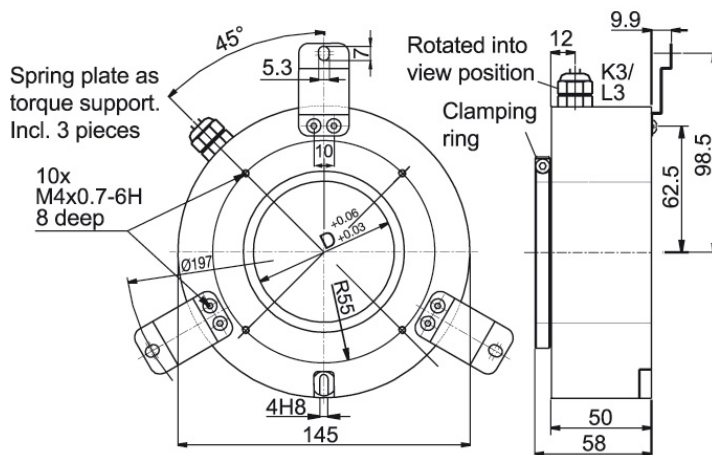
**Cable connection K3, L3 with 2 m cable**

**Description**
**ABN inv. poss.**
**K3** radial, shield not connected

•

**L3** radial, shield connected to encoder housing

•

**Assignments**

	K3, L3	K3, L3	K3, L3	K3, L3
<b>Circuit</b>	G05, G24	H05, H24	I05, I24	R05, R24
<b>GND</b>	WH	WH	WH	WH
<b>(+) Vcc</b>	BN	BN	BN	BN
<b>A</b>	GN	GN	GN	GN
<b>B</b>	YE	YE	YE	YE
<b>N</b>	GY	GY	GY	GY
<b>Light reserve warning</b>	PK	-	PK	-
<b>A inv.</b>	-	-	RD	RD
<b>B inv.</b>	-	-	BK, (BU at ACA)	BK, (BU at ACA)
<b>N inv.</b>	-	-	VT	VT
<b>Shield</b>	flex	flex	flex	flex

**Connector (M16x0.75) SH, 5-, 6-, 8-, 12-pin**

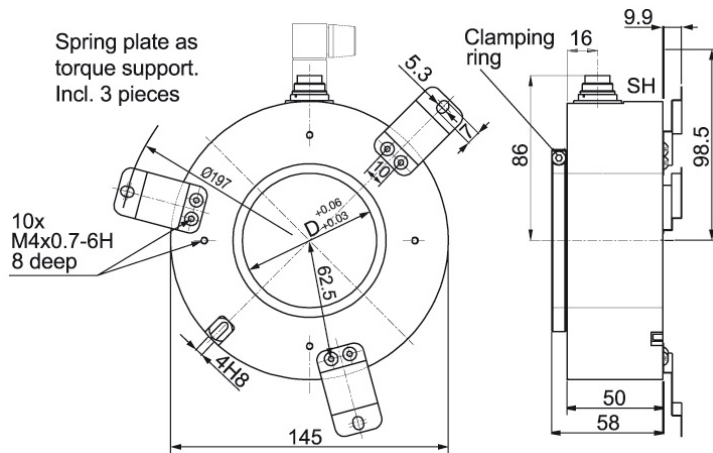

**Description**

**ABN inv. poss.**

<b>SH5</b>	radial, 5-pin, Connector connected to encoder housing	-
<b>SH6</b>	radial, 6-pin, Connector connected to encoder housing	-
<b>SH8</b>	radial, 8-pin, Connector connected to encoder housing	•
<b>SH12</b>	radial, 12-pin, Connector connected to encoder housing	•

**Assignments**

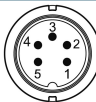
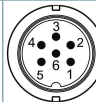
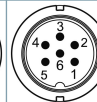
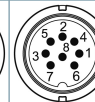
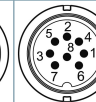
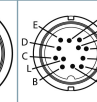
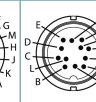
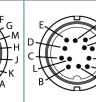
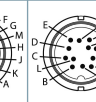
	<b>SH5</b>	<b>SH6</b>	<b>SH6</b>	<b>SH8</b>	<b>SH8</b>	<b>SH12</b>	<b>SH12</b>	<b>SH12</b>	<b>SH12</b>
	<b>5-pin</b>	<b>6-pin</b>	<b>6-pin</b>	<b>8-pin</b>	<b>8-pin</b>	<b>12-pin</b>	<b>12-pin</b>	<b>12-pin</b>	<b>12-pin</b>
									
<b>Circuit</b>	H05, H24	G05, G24	H05, H24	H05, H24	R05, R24	G05, G24	H05, H24	I05, I24	R05, R24
<b>GND</b>	1	6	6	1	1	K, L	K, L	K, L	K, L
<b>(+) Vcc</b>	2	1	1	2	2	M, B	M, B	M, B	M, B
<b>A</b>	3	2	2	3	3	E	E	E	E
<b>B</b>	4	4	4	4	4	H	H	H	H
<b>N</b>	5	3	3	5	5	C	C	C	C
<b>Light reserve warning</b>	-	5	-	-	-	G	-	G	-
<b>A inv.</b>	-	-	-	-	6	-	-	F	F
<b>B inv.</b>	-	-	-	-	7	-	-	A	A
<b>N inv.</b>	-	-	-	-	8	-	-	D	D
<b>n. c.</b>	-	-	5	6, 7, 8	-	A, D, F, J	A, D, F, G, J	J	G, J
<b>Shield</b>	-	-	-	-	-	-	-	-	-

**Connector (M16x0.75) S3, 7-pin**

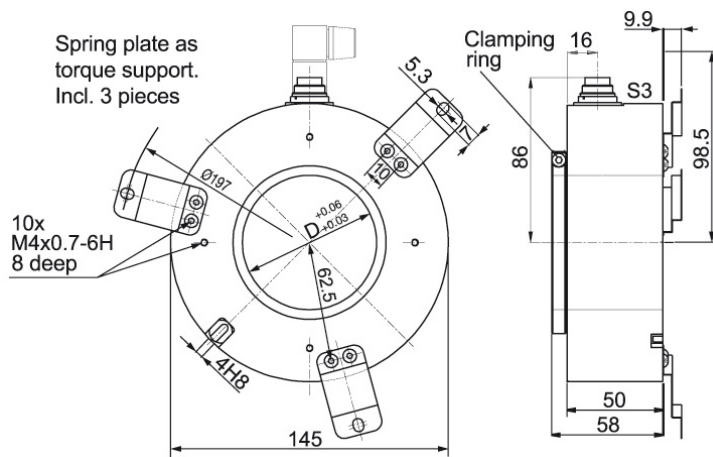

**Description**

**ABN inv. poss.**

**S3** radial, 7-pin, Connector connected to encoder housing

-

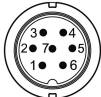
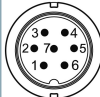
Assignments		
	<b>S3</b>	<b>S3</b>
	<b>7-pin</b>	<b>7-pin</b>
		
<b>Circuit</b>	G05, G24	H05, H24
<b>GND</b>	1	1
<b>(+) Vcc</b>	2	2
<b>A</b>	3	3
<b>B</b>	4	4
<b>N</b>	5	5
<b>Light reserve warning</b>	6	-
<b>A inv.</b>	-	-
<b>B inv.</b>	-	-
<b>N inv.</b>	-	-
<b>n. c.</b>	7	6, 7
<b>Shield</b>	-	-

**Connector (M23) S5, 12-pin**

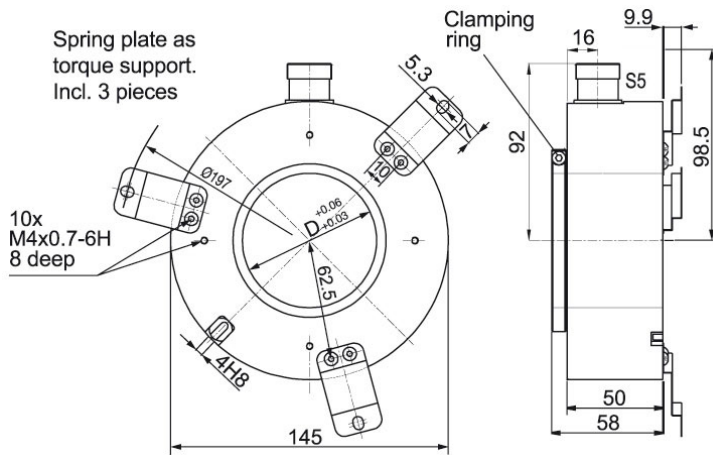





**Description**

ABN inv. poss.

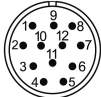
**S5** radial, 12-pin, Connector connected to encoder housing

•

Assignments				
	S5	S5	S5	S5
	12-pin	12-pin	12-pin	12-pin
				
<b>Circuit</b>	G05, G24	H05, H24	I05, I24	R05, R24
<b>GND</b>	10	10	10	10
<b>(+) Vcc</b>	12	12	12	12
<b>A</b>	5	5	5	5
<b>B</b>	8	8	8	8
<b>N</b>	3	3	3	3
<b>Light reserve warning</b>	11	-	11	-
<b>A inv.</b>	-	-	6	6
<b>B inv.</b>	-	-	1	1
<b>N inv.</b>	-	-	4	4
<b>n. c.</b>	1, 2, 4, 6, 7, 9	1, 2, 4, 6, 7, 9, 11	2, 7, 9	2, 7, 9, 11
<b>Shield</b>	-	-	-	-

**Connector (M23) S5R, 12-pin (clockwise)**

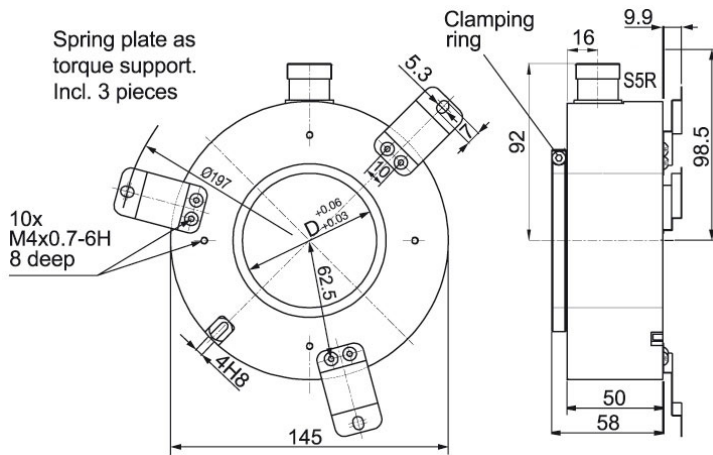

**Description**

ABN inv. poss.

**S5R** radial, 12-pin, Connector connected to encoder housing

•

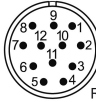
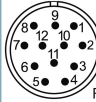
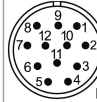
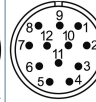
Assignments				
	S5R	S5R	S5R	S5R
	12-pin	12-pin	12-pin	12-pin
				
<b>Circuit</b>	G05, G24	H05, H24	I05, I24	R05, R24
<b>GND</b>	10	10	10	10
<b>(+) Vcc</b>	12	12	12	12
<b>A</b>	5	5	5	5
<b>B</b>	8	8	8	8
<b>N</b>	3	3	3	3
<b>Light reserve warning</b>	11	-	11	-
<b>A inv.</b>	-	-	6	6
<b>B inv.</b>	-	-	1	1
<b>N inv.</b>	-	-	4	4
<b>n. c.</b>	1, 2, 4, 6, 7, 9	1, 2, 4, 6, 7, 9, 11	2, 7, 9	2, 7, 9, 11
<b>Shield</b>	-	-	-	-



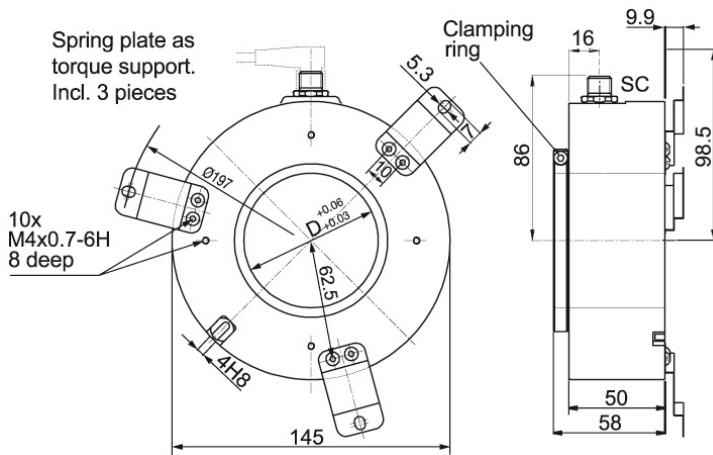

**Sensor-connector (M12x1) SC, 4-, 5-, 8-pin**



**Description**

**ABN inv. poss.**

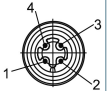
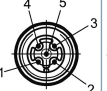
<b>SC4</b>	radial, 4-pin, Connector connected to encoder housing	-
<b>SC5</b>	radial, 5-pin, Connector connected to encoder housing	-
<b>SC8</b>	radial, 8-pin, Connector connected to encoder housing	•

Assignments				
	<b>SC4</b>	<b>SC5</b>	<b>SC8</b>	<b>SC8</b>
	<b>4-pin</b>	<b>5-pin</b>	<b>8-pin</b>	<b>8-pin</b>
				
<b>Circuit</b>	H05, H24	H05, H24	H05, H24	R05, R24
<b>GND</b>	3	3	1	1
<b>(+) Vcc</b>	1	1	2	2
<b>A</b>	2	4	3	3
<b>B</b>	4	2	4	4
<b>N</b>	-	5	5	5
<b>Light reserve warning</b>	-	-	-	-
<b>A inv.</b>	-	-	-	6
<b>B inv.</b>	-	-	-	7
<b>N inv.</b>	-	-	-	8
<b>n. c.</b>	-	-	6, 7, 8	-
<b>Shield</b>	-	-	-	-

## Options

### Cable length

### Order key

The encoder WDG 145H can be supplied with more than 2 m cable. The maximum cable length depends on the supply voltage and the frequency; see [www.wachendorff-automation.com/atd](http://www.wachendorff-automation.com/atd)

**XXX = Decimeter**

Please extend the standard order code with a three figure number, specifying the cable length in decimetres.

Example: 5 m cable = 050

### IP64 all around

### Order key

The encoder WDG 145H can be supplied in a full IP64 version.

**AEK**

Max. RPM: 500 rpm

Starting-torque: approx. 5 Ncm at ambient temperature, approx. 1.416 in-ozf at ambient temperature

Example Order No.	Type					Your encoder
WDG 145H	WDG 145H					WDG 145H
	<b>Bore size</b>					
65	45; 48; 50; 55; 60; 65; 72					
	<b>Pulses per revolution PPR:</b>					
1024	1024, 2500 Other PPRs on request					
	<b>Channels:</b>					
ABN	AB, ABN					
	<b>Output circuit</b>					
G24	<b>Resolution PPR</b>	<b>Power supply VDC</b>	<b>Output circuit</b>	<b>Light reserve warning</b>	<b>Order key</b>	
	1024, 2500	4.75 - 5.5	TTL	•	G05	
		4.75 - 5.5	TTL	-	H05	
		4.75 - 5.5	TTL, RS422 comp., inverted	•	I05	
		4.75 - 5.5	TTL, RS422 comp., inverted	-	R05	
		10 - 30	HTL	•	G24	
		10 - 30	HTL	-	H24	
		10 - 30	HTL inverted	•	I24	
10 - 30		HTL inverted	-	R24		
	<b>Electrical connections</b>					
K3	<b>Description</b>			<b>ABN inv. poss.</b>	<b>Order key</b>	
	<b>Cable: length (2 m standard, WDG 58T: 1 m)</b>					
	radial, shield not connected			•	K3	
	radial, shield connected to encoder housing			•	L3	
	<b>Connector: (shield connected to encoder housing)</b>					
	connector, M16x0.75, 5-pin, radial			-	SH5	
	connector, M16x0.75, 6-pin, radial			-	SH6	
	connector, M16x0.75, 8-pin, radial			•	SH8	
	connector, M16x0.75, 12-pin, radial			•	SH12	
	connector, M16x0.75, 7-pin, radial			-	S3	
	connector, M23, 12-pin, radial			•	S5	
	connector, clockwise pin count, M23, 12-pin, radial			•	S5R	
	sensor-connector, M12x1, 4-pin, radial			-	SC4	
	sensor-connector, M12x1, 5-pin, radial			-	SC5	
sensor-connector, M12x1, 8-pin, radial			•	SC8		
	<b>Options</b>					
	<b>Description</b>			<b>Order key</b>		
	Without option			Empty		
	IP64			AEK		
	Cable length			XXX = Decimeter		

<b>Example Order No.=</b>	WDG 145H	65	1024	ABN	G24	K3			WDG 145H						<b>Your encoder</b>
---------------------------	----------	----	------	-----	-----	----	--	--	----------	--	--	--	--	--	---------------------



For further information please contact our local distributor.  
Here you find a list of our distributors worldwide.  
[http://www.wachendorff-automation.com/distributors\\_worldwide.html](http://www.wachendorff-automation.com/distributors_worldwide.html)



Wachendorff Automation GmbH & Co. KG  
Industriestrasse 7 • D-65366 Geisenheim

Phone: +49 67 22 / 99 65 25  
Fax: +49 67 22 / 99 65 70  
E-Mail: [wdg@wachendorff.de](mailto:wdg@wachendorff.de)  
[www.wachendorff-automation.de](http://www.wachendorff-automation.de)

