

Online Data Sheet

Encoder WDGA 58E CANopen

www.wachendorff-automation.com/wdga58ecan

Wachendorff Automation

... systems and encoders

- Complete systems
- Industrial rugged encoders to suit your application
- Standard range and customer versions
- Maximum permissible loads
- 48-hour express production
- Made in Germany
- Worldwide distributor network

Encoder WDGA 58E absolute CANopen magnetic, with EnDra®-Technology



EnDra®
Technologie

CANopen®

- EnDra® multiturn technology: maintenance-free and environmentally friendly
- CANopen, Single- and Multiturn
- Communication Profile according to CiA 301
- Device Profile for encoder CiA 406 V3.2 class C2
- Single-/Multiturn (14 bit / 39 bit)
- Forward-looking technology with 32 Bit processor

www.wachendorff-automation.com/wdga58ecan

Mechanical Data	
Housing	
Flange	hollow shaft (blind-bored)
Flange material	aluminium
Housing cap	steel case chrome-plated, magnetic shielding
Torque supports	incl. 1 torque support WDGDS10001
- 1. Spring plate compensation	axial: ±0.8 mm, radial: ±0.2 mm
- Max. operating speed	6000 rpm up to max. protection rating +60 °C
- 2. Cylinder pin 4 mm	needs accessories WDGDS10005
- Compensation	axial: ±0.5 mm, radial: ±1.5 mm, Max. operating speed: 3000 rpm
Housing	Ø 58 mm
Shaft(s)	
Shaft material	stainless steel
Starting torque	approx. 1.6 Ncm at ambient temperature
Fixing	permanently attached clamping ring
Shaft	Ø 6 mm
Advice	with adapter sleeve
Shaft length	L: 12 mm
Insertion depth min.	11 mm
Insertion depth max.	15 mm
Max. Permissible shaft loading radial	80 N
Max. Permissible shaft loading axial	50 N
Shaft	Ø 6.35 mm
Advice	with adapter sleeve
Shaft length	L: 12 mm
Insertion depth min.	11 mm
Insertion depth max.	15 mm
Max. Permissible shaft loading radial	80 N
Max. Permissible shaft loading axial	50 N
Shaft	Ø 7 mm
Advice	with adapter sleeve
Shaft length	L: 12 mm
Insertion depth min.	11 mm
Insertion depth max.	15 mm
Max. Permissible shaft loading radial	80 N

Max. Permissible shaft loading axial	50 N
Shaft	Ø 8 mm
Advice	with adapter sleeve
Shaft length	L: 12 mm
Insertion depth min.	11 mm
Insertion depth max.	15 mm
Max. Permissible shaft loading radial	80 N
Max. Permissible shaft loading axial	50 N
Shaft	Ø 3/8", 9.525 mm, Ø 3/8"
Advice	with adapter sleeve
Shaft length	L: 12 mm
Insertion depth min.	11 mm
Insertion depth max.	15 mm
Max. Permissible shaft loading radial	80 N
Max. Permissible shaft loading axial	50 N
Shaft	Ø 10 mm
Advice	with adapter sleeve
Shaft length	L: 12 mm
Insertion depth min.	11 mm
Insertion depth max.	15 mm
Max. Permissible shaft loading radial	80 N
Max. Permissible shaft loading axial	50 N
Shaft	Ø 12 mm
Shaft length	L: 12 mm
Insertion depth min.	11 mm
Insertion depth max.	15 mm
Max. Permissible shaft loading radial	80 N
Max. Permissible shaft loading axial	50 N
Shaft	Ø 14 mm
Shaft length	L: 12 mm
Insertion depth min.	11 mm
Insertion depth max.	15 mm
Max. Permissible shaft loading radial	80 N

Max. Permissible shaft loading axial	50 N
--------------------------------------	------

Bearings

Bearings type	2 precision ball bearings
Nominale service life	1 x 10 ⁹ revs. at 100 % rated shaft load 1 x 10 ¹⁰ revs. at 40 % rated shaft load 1 x 10 ¹¹ revs. at 20 % rated shaft load
Max. operating speed	6000 rpm

Machinery Directive: basic data safety integrity level

MTTF _d	1000 a
Mission time (TM)	20 a
Nominale service life (L10h)	1 x 10 ¹¹ revs. at 20 % rated shaft load and 6000 rpm
Diagnostic coverage (DC)	0 %

Electrical Data

Power supply/Current consumption	10 VDC up to 32 VDC: max. 50 mA
Power consumption	max. 0.5 W

Sensor data

Singleturn technology	innovative hall sensor technology
Singleturn resolution	16,384 steps/360° (14 bit)
Singleturn accuracy	< ±0.35°
Singleturn repeat accuracy	< ±0.20°
Intern cycle time	600 µs
Multiturn technology	patented EnDra® technology no battery and no gear.
Multiturn resolution	up to 262,144 revolutions (18 bit) with high precision value up to 39 bit.

Environmental data

ESD (DIN EN 61000-4-2):	8 kV
Burst (DIN EN 61000-4-4):	2 kV
includes EMC:	DIN EN 61000-6-2 DIN EN 61000-6-3
Vibration: (DIN EN 60068-2-6)	50 m/s ² (10 Hz up to 2000 Hz)
Shock: (DIN EN 60068-2-27)	1000 m/s ² (6 ms)
Design:	according DIN VDE 0160
Turn on time:	<1,5 s

Interface

Interface:	CAN
Protocol:	CANopen <ul style="list-style-type: none"> • Communication profil CiA 301 • Device Profile for encoder CiA 406 V3.2 class C2
Node number:	1 up to 127 (default 127)
Baud rate:	10 kBaud up to 1 MBaud with automatic bit rate detection.
Advice:	The standard settings as well as any customization in the software can be changed via LSS (CiA 305) and the SDO protocol, e. g. PDOs, Scaling, Heartbeat, Node-ID, Baud rate, etc.

Programmable CAN transmission modes:

Synchronous mode:
when a synchronisation telegram (SYNC) is received from another bus node, PDOs are transmitted independently.

Asynchronous mode:
a PDO message is triggered by an internal event. (e.g. change of measured valued, internal timer, etc.)

General Data

Weight	approx. 220 g
Connections	connector outlet
Protection rating (EN 60529)	IP67, shaft sealed to IP65
Operating temperature	-40 °C up to +85 °C
Storage temperature	-40 °C up to +100 °C

More Information

General technical data
<http://www.wachendorff-automation.com/gtd>

Options
<http://www.wachendorff-automation.com/acc>

Connector, M12x1 CC5, 5-pin

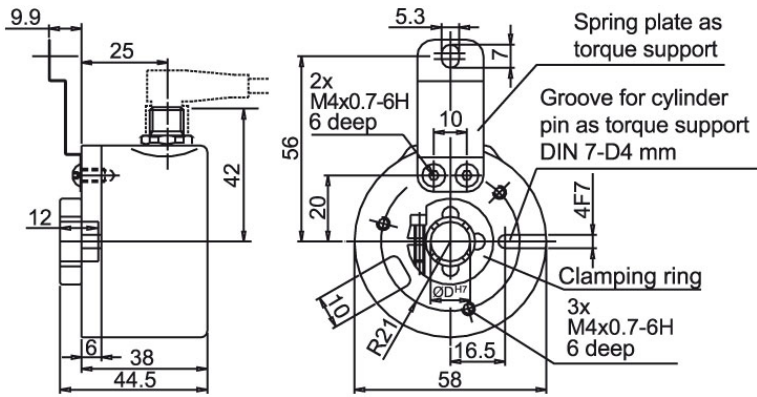

Description

CC5 radial, 5-pin, shield connected to encoder housing

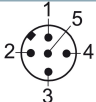
Assignments	
	CC5 
(+) Vcc	2
GND	3
CANHigh	4
CANLow	5
CANGND shield	1

Example Order No.	Type	Your encoder
WDGA 58E	WDGA 58E	WDGA 58E
	Shaft	Order key
06	Ø 6 mm with adapter sleeve	06
	Ø 6.35 mm with adapter sleeve	2Z
	Ø 7 mm with adapter sleeve	07
	Ø 8 mm with adapter sleeve	08
	Ø 3/8", 9.525 mm Ø 3/8" with adapter sleeve	4Z
	Ø 10 mm with adapter sleeve	10
	Ø 12 mm	12
	Ø 14 mm	14
	Singleturn Resolution	Order key
12	Singleturn resolution 1 Bit up to 14 Bit: (e. G. 12 Bit)	12
	Multiturn Resolution	Order key
18	Multiturn-resolution: (examples) 18 bit = 18 39 bit = 39 no Multiturn = 00	18
	Data protocol	Order key
CO	CANopen	CO
	Software	Order key
A	up to date release	A
	Code	Order key
B	binary	B
	Power supply	Order key
0	10 V up to 32 V (standard)	0
	Galvanic isolation	Order key
0	no	0
	Electrical connections	Order key
CC5	Connector: sensor-connector, M12x1, 5-pin, radial, IP67, shield connected to encoder housing	CC5

Example Order No.	WDGA 58E	06	12	18	CO	A	B	0	0	CC5
--------------------------	----------	----	----	----	----	---	---	---	---	-----

WDGA 58E										Example Order No.
----------	--	--	--	--	--	--	--	--	--	--------------------------



For further information please contact our local distributor.
Here you find a list of our distributors worldwide.
http://www.wachendorff-automation.com/distributors_worldwide.html



Wachendorff Automation GmbH & Co. KG
Industriestrasse 7 • D-65366 Geisenheim

Phone: +49 67 22 / 99 65 25
Fax: +49 67 22 / 99 65 70
E-Mail: wdg@wachendorff.de
www.wachendorff-automation.de

